



Compressor type

V105, V150, V200, V250, **V375**

Dear Sirs,
We offer brand new Hamforthy
Hatlapa)Compressor. Pls see pdf file with photos.
Classification Society is ABS.
Price - \$45,000
2 sets on stock in US
(subject unsold).
Please contact with Viktor
broverttek@gmail.com



Structural features:

Two cylinder, two stage single acting 90° V-configuration machine, with a single throw crankshaft

Valves:

State of the art concentric valves with combined suction and delivery on both stages

Water cooling:

Fresh water cooling,

~~optionally fitted with water circulation pump~~

Intercooler and aftercooler:

High efficiency built-in tubular interstage and aftercooler
Integral 1st and 2nd stage high efficiency oil and water separators

Unloader:

1st and 2nd stage solenoid drain/unloading valves

Lubrication:

Splash lubrication system (V105, V150, V375)
Force feed lubrication system (V200, V250)

Bearings:

Small end con. rod bearings: needle type both stages

Crankshaft:

taper roller bearings (V105, V150, V375)

Slide bearings (V200, V250)

Big end con. rod bearings:

cylindrical roller bearings both stages (V105, V150, V375)

Slide bearings (V200, V250)

Compressor type

V105, V150, V200, V250, V375

HATLAPA

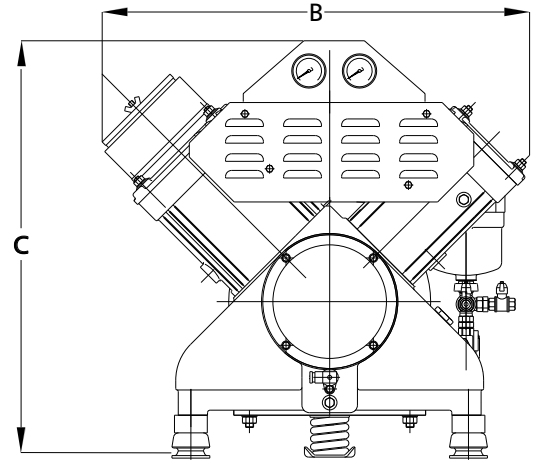
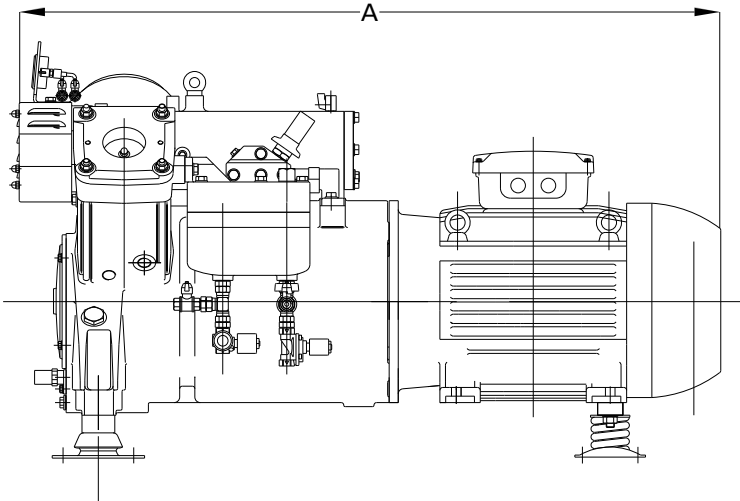

| TYPE | Cylinders qt. | Stages qt. | Speed r.p.m. | F.A.D. m ³ /h | Power kW | Weight incl. e-motor approx. kg | Dimensions | | |
|------|------------------|---------------|-----------------|-----------------------------|-------------|------------------------------------|------------|------|------|
| | | | | | | | A | B | C |
| V105 | 2 | 2 | 1000 | 55 | 13 | 620 | 1310 | 840 | 676 |
| | | | 1200 | 70 | 15.5 | 620 | 1310 | 840 | 676 |
| | | | 1500 | 85 | 20 | 620 | 1310 | 840 | 676 |
| | | | 1800 | 105 | 22 | 620 | 1310 | 840 | 676 |
| V150 | 2 | 2 | 1000 | 80 | 18 | 650 | 1335 | 840 | 755 |
| | | | 1200 | 100 | 20 | 650 | 1335 | 840 | 755 |
| | | | 1500 | 120 | 27 | 650 | 1335 | 840 | 755 |
| | | | 1800 | 150 | 30 | 650 | 1335 | 840 | 755 |
| V200 | 2 | 2 | 950 | 110 | 19.2 | 1100 | 1525 | 1000 | 860 |
| | | | 1150 | 132 | 23.6 | | | | |
| | | | 1450 | 166 | 31 | | | | |
| | | | 1750 | 200 | 38.7 | | | | |
| V250 | 2 | 2 | 950 | 137 | 25 | 1100 | 1525 | 1000 | 860 |
| | | | 1150 | 165 | 31 | | | | |
| | | | 1450 | 206 | 41 | | | | |
| | | | 1750 | 245 | 50 | | | | |
| V375 | 2 | 2 | 1000 | 210 | 38 | 1460 | 1755 | 1160 | 1054 |
| | | | 1200 | 250 | 49 | | | | |
| | | | 1500 | 310 | 58 | | | | |
| | | | 1800 | 375 | 73 | | | | |

All data apply to a final pressure of 30 bar. The right for alteration of specification and data to incorporate improvements in design is reserved.

- Motor ①
- Flywheel and coupling ②
- Solenoid valve for draining ③
- Non-return valve ④
- Pressure switch ⑤
- Oil and water separator ⑥
- Flexible hoses ⑦

